



Construction No. 539
TGKX.539
Roof Deck Constructions

[Page Bottom](#)

Design/System/Construction/Assembly Usage Disclaimer

- Authorities Having Jurisdiction should be consulted in all cases as to the particular requirements covering the installation and use of UL Listed or Classified products, equipment, system, devices, and materials.
 - Authorities Having Jurisdiction should be consulted before construction.
 - Fire resistance assemblies and products are developed by the design submitter and have been investigated by UL for compliance with applicable requirements. The published information cannot always address every construction nuance encountered in the field.
 - When field issues arise, it is recommended the first contact for assistance be the technical service staff provided by the product manufacturer noted for the design. Users of fire resistance assemblies are advised to consult the general Guide Information for each product category and each group of assemblies. The Guide Information includes specifics concerning alternate materials and alternate methods of construction.
 - Only products which bear UL's Mark are considered as Classified, Listed, or Recognized.
-

Roof Deck Constructions

[See General Information for Roof Deck Constructions](#)

Construction No. 539

February 22, 2012

Uplift — Class 90

Fire Not Investigated

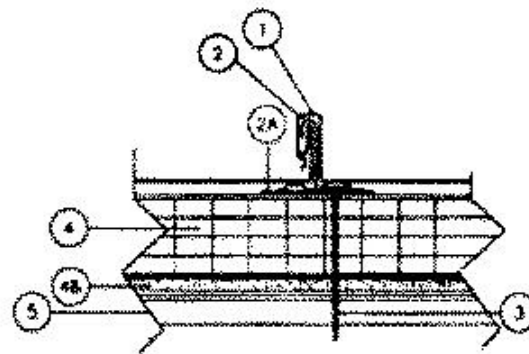
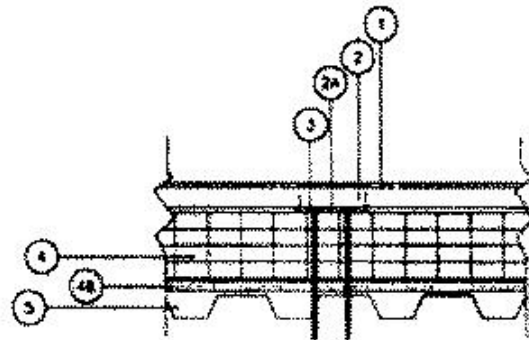
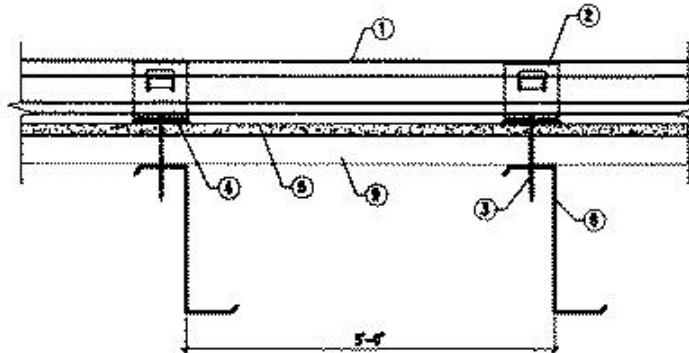
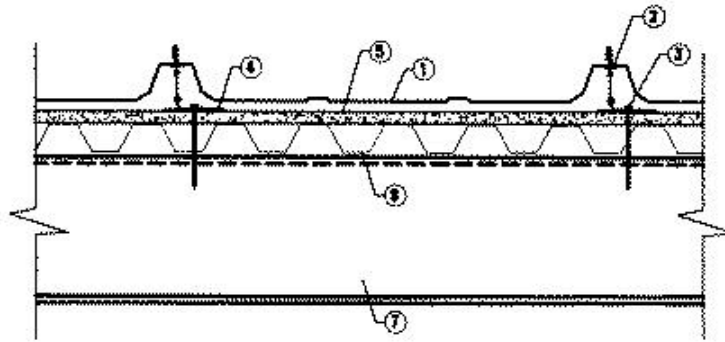

1. **Metal Roof Deck Panels*** — No. 24 MSG min. Coated steel panels continuous over two or more spans. End laps to occur adjacent to purlins with panels overlapped 3 inch max. Side laps to be tightened and crimped with a special

motorized crimping machine. A line of sealant may be used at panel end and side laps.

A & S BUILDING SYSTEMS L P ([View Classification](#)) — "Double-Lok"

B C STEEL BUILDINGS INC ([View Classification](#)) — "BCL-MS"

CENTRAL STATES MFG INC ([View Classification](#)) — "Central-Seam Plus"

CENTRAL TEXAS METAL ROLLFORMING INC ([View Classification](#)) — "SPANLOC 300"

CHIEF INDUSTRIES INC ([View Classification](#)) — "MSC".

GOLDEN EMPIRE MFG INC, DBA GEM

BUILDINGS ([View Classification](#)) — "GEM Superior-24"

MBCI ([View Classification](#)) — "Double-Lok"

MCELROY METAL MILL INC ([View Classification](#)) — "MASTERLOK FS"

MESCO METAL BUILDINGS ([View Classification](#)) — "Double-Lok"

NCI BUILDING SYSTEMS L P ([View Classification](#)) — "Double-Lok" or "Triple-Lok"

PINNACLE STRUCTURES INC ([View Classification](#)) — "PINNACLE D-LOK"

UNITED STRUCTURES OF AMERICA INC ([View Classification](#)) — "Guardian-Lok"

WHIRLWIND STEEL BUILDINGS INC ([View Classification](#)) — "Super-Seam Plus"

ZIMMERMAN METALS INC ([View Classification](#)) — "TSS-3000"

2. **Roof Deck Fasteners*** — (Panel Clips)-Two piece floating clip with a min No. 14 MSG coated steel base and a min No. 22 MSG coated steel top. Clips spaced at 60-1/4 inches on center and over purlins.

BUILDING PRODUCTS DEVELOPMENT INC ([View Classification](#)) — "NC34501", "NC34502", "NC34701", "NC34702"

CHIEF INDUSTRIES INC ([View Classification](#)) — "MSC Sliding Clip"

GOLDEN EMPIRE MFG INC, DBA GEM

BUILDINGS ([View Classification](#)) — "GEM Low Superior Clip", "GEM High Superior Clip"

NCI BUILDING SYSTEMS L P ([View Classification](#)) — "High or Low Floating Clip" or "Double-Lok Floating Clip" or "Double-Lok Sliding Clip" or "Triple-Lok Sliding Clip" or "Double-Lok 2" Sliding Hi-Thermal Clip".

2a. **Roof Deck Fasteners*** — (Panel Clips)-Two piece floating clip with a No. 16 MSG coated steel base and a No. 20 MSG coated steel top. Clips spaced at 60-1/4 inches on center and over purlins.

MCELROY METAL MILL INC ([View Classification](#)) — "Low Floating", "High Floating" or "Utility Floating"

3. Fasteners — (Screws)-Fasteners for panel clips and bearing plates (Item No. 2 and 4A) through rigid insulation (or optional plywood when bearing plates are not used) and into metal deck (Item No. 7) to be No. 14 type Phillips head. Two screws per clip. Fastener length to be 1/2 inch longer than the total thickness of the plywood (Item No. 4), rigid board (Item No. 6) and metal deck (Item No. 7). Screws used at the end lap to be 1/4-14 by 1 inch long with 3/8 inch hex-head and separate 5/8 inch neoprene and steel washer. Six (6) fasteners are to be used in the flat section of the end lap panel with the first fastener located 3-1/4 inches from either rib and then spaced in a 3-1/2, 3-1/2, 3-1/2, 3-1/2 inch pattern. An additional fastener is to be located at the second slanted segment of the rib on both sides of the end lap panel. Fasteners used with alternate 16 MSG min. thick coated steel upper section to be No. 14 by 1 inch long self-tapping fastener. First fastener located 3/8 inch from first slanted segment in a 4, 5-1/2, 5-1/2, 4 inch pattern. Screws used to attach optional plywood substructure (Item No. 4) to the metal deck (Item No. 7) to be No. 14 type with Phillips head. Fastener length to be a minimum of 1/2 inch longer than the total thickness of the plywood, insulation and metal deck. Spacing to be 6 inches O.C. at plywood, ends and 12 inch O.C. at a 2 foot pattern down the length of the plywood (total of 33 fasteners per 4 by 8 foot plywood sheet). (Alternate-When bearing plates replace plywood). An optional No. 10 by 1 inch self-drilling fastener may be used to attach clip to bearing plate when installer chooses to install rigid board insulation and use the bearing plates to hold it in place until clips and panels are installed.

4. Substructure — (Plywood)-(optional)-(not shown)-Plywood decking to be a nom 1/2 inch thick, exposure sheathing span C-D 40/20 plywood. To be used in lieu of bearing plates (Item No. 4A). When plywood is used the rigid insulation (Item No. 6) maximum thickness is 4 inches.

4A. Substructure — (Bearing Plates)-(optional)-To be used in lieu of plywood (Item No. 4) with rigid insulation (Item No. 6) maximum thickness of 4.4 inches. Bearing plates to be 16 MSG minimum coated steel. Located under each clip, for support.

5. Thermal Spacer — (optional)—Polystyrene, 1 inch max thickness, 3 inches wide, cut to fit between panel clips.

6. Rigid Insulation — Foamed plastic, minimum 1 inch thickness, maximum thickness 4-1/2 inches when plywood is used and 6 inches when bearing plates are used. Density to be a min. 2 pcf.

6A. Waterproof Membrane — (optional)(not shown) Used to protect plywood (Item 4). Installed under panels (Item 1).

7. Metal Deck — 22 MSG minimum thickness coated steel, Min. depth 1-1/2 inches with ribs at 6 inch O.C. End lap to be 4 inch min. and occur over purlin. Metal deck to be welded to purlins in every other flute, except for the end laps which are welded in every low flute.

8. End-Lap Plate Assembly — (not shown)-Used at panel end laps; Consisting of a lower section, 5-5/8 inches wide, with a 1/8 inch vertical leg, formed to the general profile of the panel and having four 1 inch wide by 3/4 inch long tabs for sliding over the panel end. Upper section (optional) to be 1-1/2 inches wide 24 inches long and also formed to the general profile of the panel. Both parts fabricated from No. 16 MSG thick coated steel.

8B. End-Lap Assembly (Alternate) (Optional) (Stud Plate and Cinch Strap) (Not Shown) — As an alternate to End-Lap Plate Assembly (Items 8). Stud Plate (16 MSG Galv.) placed on top of purlin (Item 9) with the first stud located 1-31/32 in. from either rib and then spaced in a 4, 4-1/8, 2-3/8, 4-1/8, 4 in. pattern. Upper and Lower pre-punched metal roof deck panels (Item 1), with pre-cut tape sealer, to accommodate stud locations are positioned to receive Stud Plate. Cinch Strap (0.100 in. thick aluminum) placed over studs that penetrate both lower and upper panels. Flange nut, 1/4 in. dia., hand installed on each stud. Roof Deck Fastener (Panel Clip), Item 2, installed over male leg of panel at purlin location and secured as described in Fasteners (screws) (Item3).

9. Purlin — Minimum 14 MSG steel (55,000 psi min. yield strength).

*Bearing the UL Classification Mark

Last Updated on 2012-02-22

[Questions?](#)

[Print this page](#)

[Notice of Disclaimer](#)

[Page Top](#)

© 2012 UL LLC

The appearance of a company's name or product in this database does not in itself assure that products so identified have been manufactured under UL's Follow-Up Service. Only those products bearing the UL Mark should be considered to be Listed and covered under UL's Follow-Up Service. Always look for the Mark on the product.

UL permits the reproduction of the material contained in the Online Certification Directory subject to the following conditions: 1. The Guide Information, Designs and/or Listings (files) must be presented in their entirety and in a non-misleading manner, without any manipulation of the data (or drawings). 2. The statement "Reprinted from the Online Certifications Directory with permission from UL" must appear adjacent to the extracted material. In addition, the reprinted material must include a copyright notice in the following format: "© 2012 UL LLC".